

Work, Energy and Power

AS-Level Worksheet

MJ23/22/Q2

Q1 (a) State what is meant by the centre of gravity of an object.

.....
..... [1]

(b) Two blocks are on a horizontal beam that is pivoted at its centre of gravity, as shown in Fig. 2.1.

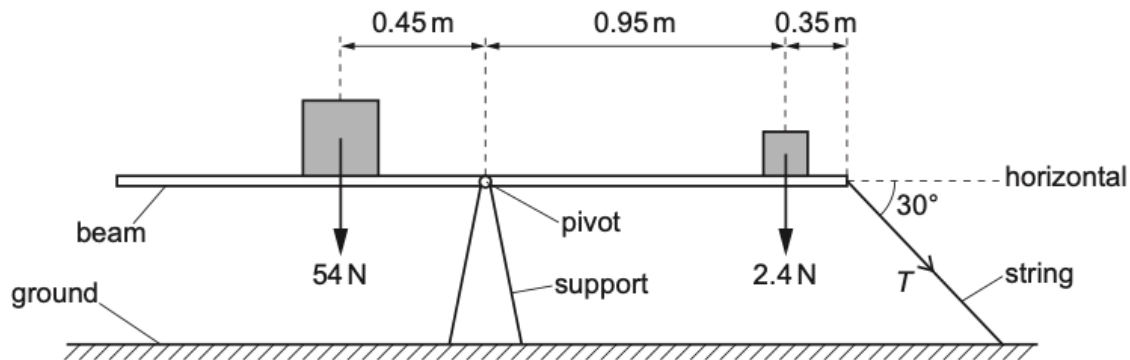

Fig. 2.1 (not to scale)

A large block of weight 54 N is a distance of 0.45 m from the pivot. A small block of weight 2.4 N is a distance of 0.95 m from the pivot and a distance of 0.35 m from the right-hand end of the beam.

The right-hand end of the beam is connected to the ground by a string that is at an angle of 30° to the horizontal. The beam is in equilibrium.

(i) By taking moments about the pivot, calculate the tension T in the string.

$T = \dots\dots\dots$ N [3]

- (ii) The string is cut so that the beam is no longer in equilibrium.

Calculate the magnitude of the resultant moment about the pivot acting on the beam immediately after the string is cut.

resultant moment =Nm [1]

- (c) The beam in (b) rotates when the string is cut and the small block of weight 2.4 N is projected through the air. Fig. 2.2 shows the last part of the path of the block before it hits the ground at point Y.

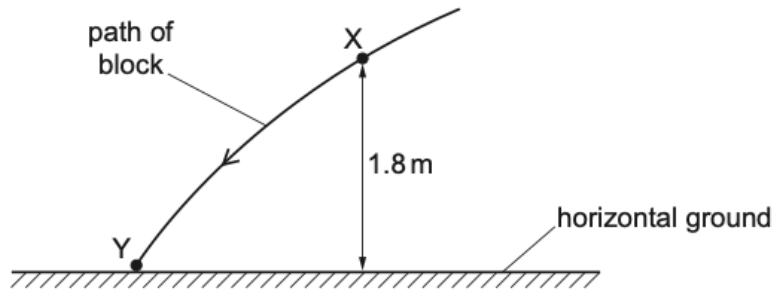

Fig. 2.2 (not to scale)

At point X on the path, the block has a speed of 3.4 m s^{-1} and is at a height of 1.8 m above the horizontal ground. Air resistance is negligible.

- (i) Calculate the decrease in the gravitational potential energy of the block for its movement from X to Y.

decrease in gravitational potential energy = J [2]

- (ii) Use your answer to (c)(i) and conservation of energy to determine the kinetic energy of the block at Y.

kinetic energy = J [3]

- (iii) State the variation, if any, in the direction of the acceleration of the block as it moves from X to Y.

..... [1]

- (iv) The block passes point X at time t_X and arrives at point Y at time t_Y .

On Fig. 2.3, sketch a graph to show the variation of the magnitude of the horizontal component of the velocity of the block with time from t_X to t_Y . Numerical values are not required.

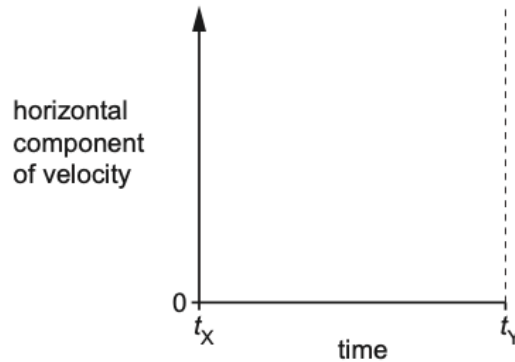

Fig. 2.3

[1]

[Total: 12]

MJ23/21/Q2

- Q2** A rigid uniform beam of weight W is connected to a fixed support by a hinge, as shown in Fig. 2.1.

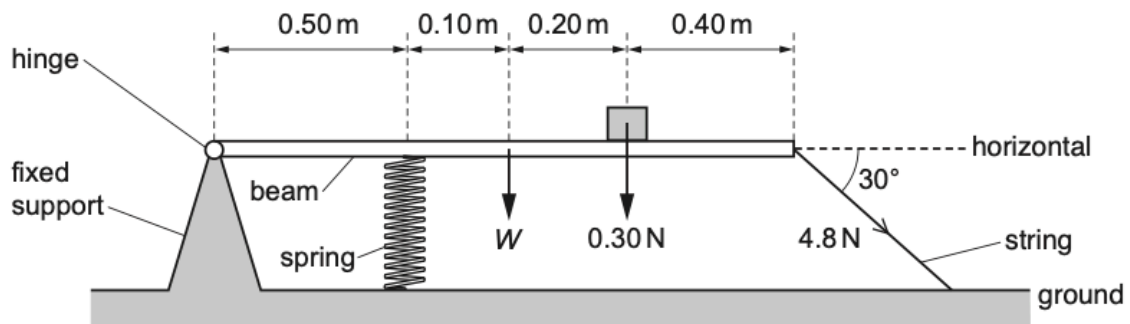

Fig. 2.1 (not to scale)

A compressed spring exerts a total force of 8.2 N vertically upwards on the horizontal beam. A block of weight 0.30 N rests on the beam. The right-hand end of the beam is connected to the ground by a string at an angle of 30° to the horizontal. The tension in the string is 4.8 N. The distances along the beam are shown in Fig. 2.1.

The beam is in equilibrium. Assume that the hinge is frictionless.

(a) (i) Show that the vertical component of the tension in the string is 2.4 N.

[1]

(ii) By taking moments about the hinge, determine the weight W of the beam.

$W = \dots\dots\dots$ N [3]

(iii) Calculate the horizontal component of the force exerted on the beam by the hinge.

force = $\dots\dots\dots$ N [1]

(c) The string is cut so that the spring extends upwards. This causes the beam to rotate and launch the block into the air. The block reaches its maximum height and then falls back to the ground.

Fig. 2.2 shows part of the path of the block in the air shortly before it hits the horizontal ground.

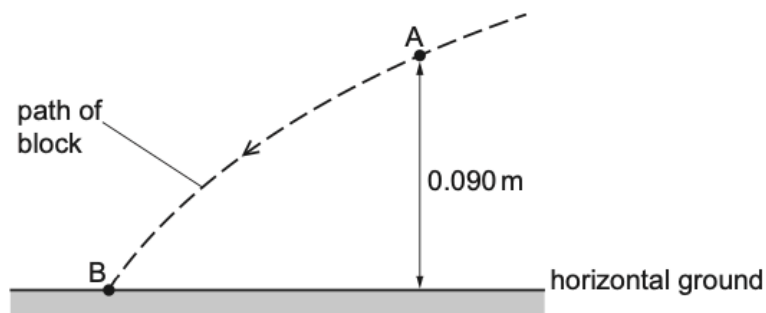

Fig. 2.2 (not to scale)

The block is at a height of 0.090m above the ground when it passes through point A. The block has a kinetic energy of 0.044 J when it hits the ground at point B. Air resistance is negligible.

- (i) Calculate the decrease in the gravitational potential energy of the block for its movement from A to B.

decrease in gravitational potential energy = J [2]

- (ii) Use your answer in (c)(i) and conservation of energy to determine the speed of the block at point A.

speed = ms^{-1} [3]

- (iii) By reference to the force on the block, explain why the horizontal component of the velocity of the block remains constant as it moves from A to B.

.....
 [1]

- (iv) The block passes through point A at time t_A and arrives at point B at time t_B .

On Fig. 2.3, sketch a graph to show the variation of the magnitude of the vertical component v_Y of the velocity of the block with time t from $t = t_A$ to $t = t_B$. Numerical values of v_Y are not required.

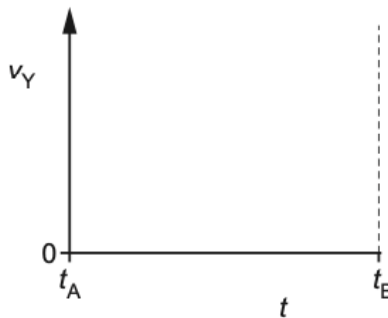

Fig. 2.3

Q3 (a) (i) Define power.

ON22/21/Q3

.....
..... [1]

(ii) Mechanical power P can be calculated using the formula $P = Fv$.

Use the concept of work and the definition of power to show how this formula is derived.

[2]

(b) The engine of a lorry provides 130 kW of power to the lorry's wheels when it is travelling at a constant speed of 25 m s^{-1} along a straight horizontal road.

Show that the resistive force opposing the forward motion of the lorry is 5200 N.

[1]

(c) The lorry in (b) travels up a straight section of road that is inclined at an angle θ to the horizontal, as shown in Fig. 3.1.

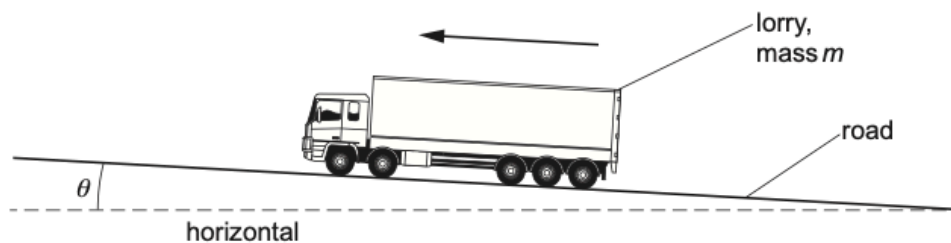

Fig. 3.1 (not to scale)

The lorry has mass m and the acceleration of free fall is g .

- (i) Determine an expression, in terms of m , g and θ , for the component of the weight of the lorry that acts parallel to the surface of the road.

[1]

- (ii) The total resistive force remains unchanged at 5200 N and the engine now provides greater power to maintain the speed of 25 m s^{-1} . The total mass m of the lorry is 36 000 kg. The angle θ is 1.4° .

Determine the power, in kW, now provided by the engine.

power = kW [3]

[Total: 8]

Q4 (a) (i) Define power.

MJ22/21/Q3

.....
..... [1]

(ii) A force F takes time t to move an object through a displacement x at constant velocity v in the direction of the force. The work done by the force is W .

Use the definition of power to show that the power P transferred by the force is given by

$$P = Fv.$$

[2]

(b) A block is pulled up a slope by a wire attached to a motor, as shown in Fig. 3.1.

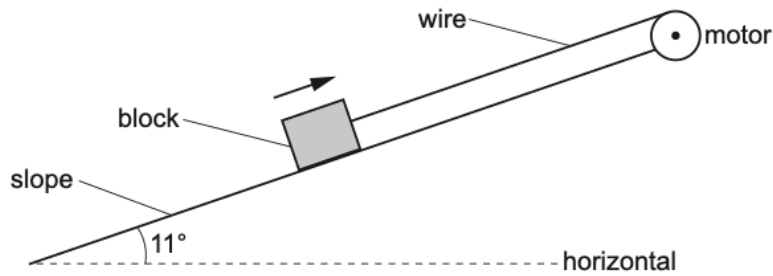

Fig. 3.1 (not to scale)

The useful power output of the motor is 56W. The block has a weight of 430N and travels with constant velocity along the slope at an angle of 11° to the horizontal.

Assume that there are no resistive forces opposing the motion of the block.

(i) Calculate the tension T in the wire.

$T =$ N [2]

(ii) Calculate the speed of the block.

speed = ms^{-1} [1]

(iii) The rate of increase of gravitational potential energy of the block is equal to the useful power output of the motor. One of the reasons for this is that there is no work done against resistive forces.

By considering the motion of the block, state another reason for this.

.....
..... [1]

(iv) The motor has an efficiency of 80%.

Calculate the time taken for an input energy of 1.2kJ to be supplied to the motor.

time taken = s [2]

[Total: 9]

- Q5 (a) A mass m moves a vertical distance Δh in a uniform gravitational field and gains gravitational potential energy ΔE_p . The acceleration of free fall is g .

Use the concept of work done to show that

$$\Delta E_p = mg\Delta h.$$

[2]

- (b) A 0.60 kg mass is attached to a string which is wrapped around the wheel of a generator, as shown in Fig. 4.1.

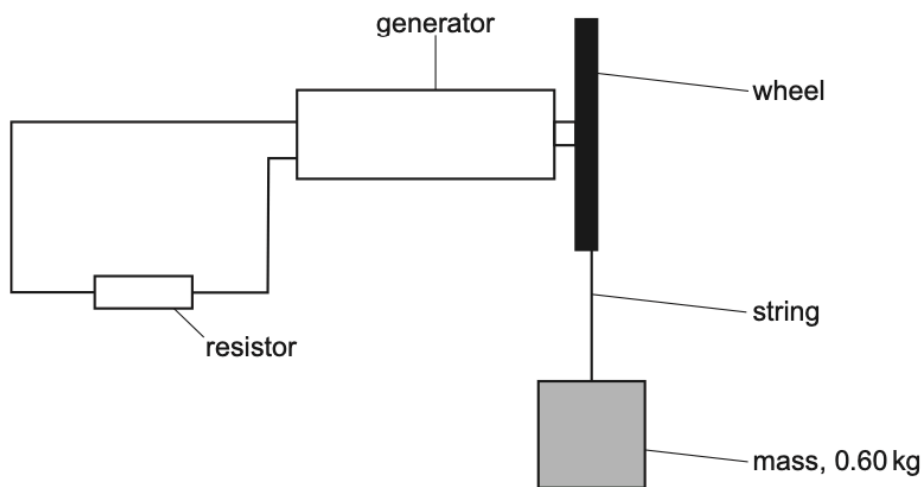

Fig. 4.1

The mass is held stationary above the floor. When released, the mass initially accelerates and then falls at a steady speed and spins the wheel. The generator causes a current in a resistor. Air resistance is negligible.

State the main energy change when the mass is falling at a steady speed.

..... energy to energy. [1]

(c) When falling at a steady speed, the mass in (b) falls through a vertical distance of 1.4 m in a time of 4.0 s. This causes a current of 90 mA in the resistor. The resistance of the resistor is 47Ω .

Calculate:

(i) the rate of work done by the falling mass

rate of work done = W [2]

(ii) the power dissipated in the resistor

power = W [2]

(iii) the efficiency of the generator.

efficiency = [2]

[Total: 9]

Q6 A child moves down a long slide, as shown in Fig. 4.1.

March22/22/Q4

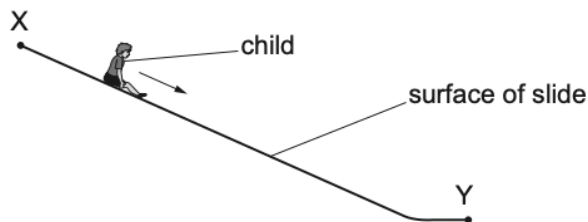

Fig. 4.1 (not to scale)

The child moves from rest at the top end X of the slide. An average resistive force of 76 N opposes the motion of the child as they move to the lower end Y of the slide. The kinetic energy of the child at Y is 300 J. The decrease in gravitational potential energy of the child as it moves from X to Y is 3200 J.

(a) Determine the ratio

$$\frac{\text{kinetic energy of the child at Y when the resistive force is 76 N}}{\text{kinetic energy of the child at Y if there is no resistive force}}$$

ratio = [1]

(b) Use the answer in **(a)** to calculate the ratio

$$\frac{\text{speed of the child at Y when the resistive force is 76 N}}{\text{speed of the child at Y if there is no resistive force}}$$

ratio = [2]

(c) Calculate the length of the slide from X to Y.

length = m [2]

Q7 (a) Define *power*.

ON21/22/Q3

.....
..... [1]

(b) A car of mass 1700 kg moves in a straight line along a slope that is at an angle θ to the horizontal, as shown in Fig. 3.1.

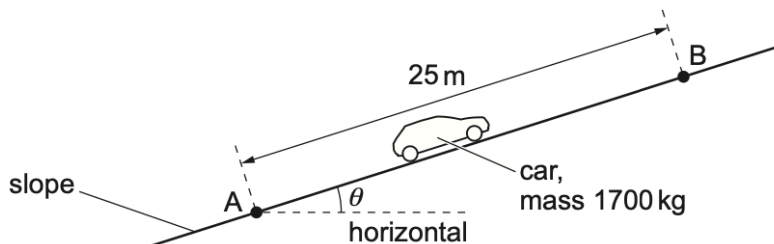

Fig. 3.1 (not to scale)

The car moves at constant velocity for a distance of 25 m from point A to point B. Air resistance and friction provide a total resistive force of 440 N that opposes the motion of the car.

For the movement of the car from A to B:

(i) state the change in the kinetic energy

change in kinetic energy = J [1]

(ii) calculate the work done against the total resistive force.

work done = J [1]

(c) The movement of the car in (b) from A to B causes its gravitational potential energy to increase by $4.8 \times 10^4 \text{ J}$.

Calculate:

(i) the increase in vertical height h of the car for its movement from A to B

$h = \dots\dots\dots \text{ m}$ [2]

(ii) angle θ .

$\theta = \dots\dots\dots^\circ$ [1]

(d) The engine of the car in (b) produces an output power of $1.7 \times 10^4 \text{ W}$ to move the car along the slope.

Calculate the time taken for the car to move from A to B.

time = $\dots\dots\dots \text{ s}$ [2]

[Total: 8]

Q8 A person uses a trolley to move suitcases at an airport. The total mass of the trolley and suitcases is 72 kg.

(a) The person pushes the trolley and suitcases along a horizontal surface with a constant speed of 1.4 m s^{-1} and then releases the trolley. The released trolley moves in a straight line and comes to rest. Assume that a constant total resistive force of 18 N opposes the motion of the trolley and suitcases.

(i) Calculate the power required to overcome the total resistive force on the trolley and suitcases when they move with a constant speed of 1.4 m s^{-1} .

power = W [2]

(ii) Calculate the time taken for the trolley to come to rest after it is released.

time = s [3]

(b) At another place in the airport, the trolley and suitcases are on a slope, as shown in Fig. 2.1.

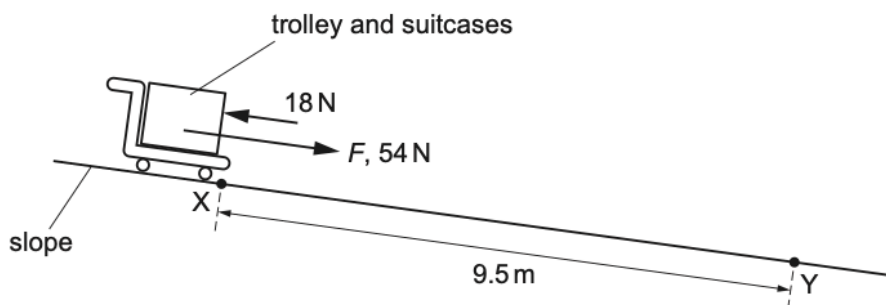

Fig. 2.1 (not to scale)

The person releases the trolley from rest at point X. The trolley moves down the slope in a straight line towards point Y. The distance along the slope between points X and Y is 9.5 m.

The component F of the weight of the trolley and suitcases that acts along the slope is 54 N. Assume that a constant total resistive force of 18 N opposes the motion of the trolley and suitcases.

(i) Calculate the speed of the trolley at point Y.

speed = ms^{-1} [3]

(ii) Calculate the work done by F for the movement of the trolley from X to Y.

work done = J [1]

(iii) The trolley is released at point X at time $t = 0$.

On Fig. 2.2, sketch a graph to show the variation with time t of the work done by F for the movement of the trolley from X to Y.

Numerical values of the work done and t are not required.

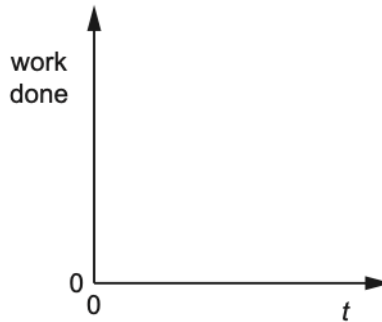

Fig. 2.2

[2]

(c) The angle of the slope in (b) is constant. The frictional forces acting on the wheels of the moving trolley are also constant.

Explain why, in practice, it is incorrect to assume that the total resistive force opposing the motion of the trolley and suitcases is constant as the trolley moves between X and Y.

.....
..... [1]

[Total: 12]

- Q9** A child of weight 330 N is at point X at the top of a slide. The slide is at the edge of a swimming pool, as shown in Fig. 3.1.

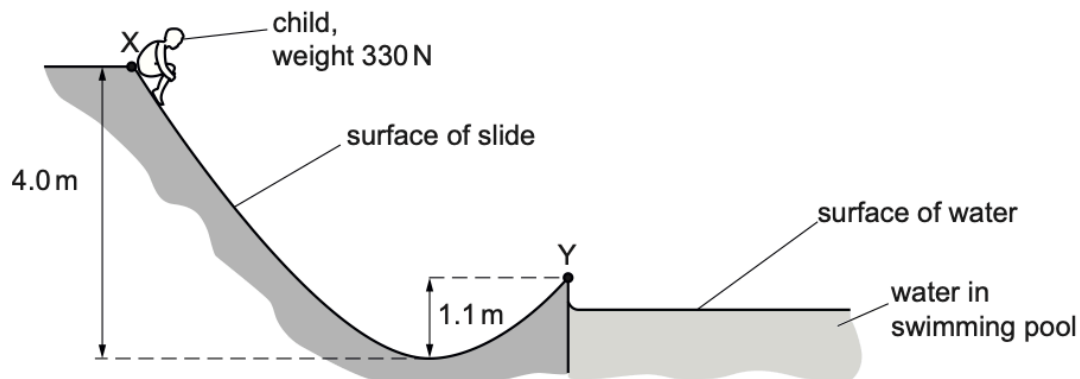

Fig. 3.1 (not to scale)

The child moves from rest to the lowest point of the slide that is a vertical distance of 4.0 m below X. The child continues moving towards point Y which is at the end of the slide and a vertical distance of 1.1 m above the lowest point. The kinetic energy of the child at Y is 540 J.

- (a) Calculate the difference in the gravitational potential energy of the child at points X and Y.

difference in gravitational potential energy = J [2]

- (b) An average frictional force of 52 N acts on the child when moving from X to Y.

By considering changes of energy, determine the distance moved by the child from X to Y.

distance moved = m [2]

- (c) The child leaves the slide at point Y with a velocity that is at an angle of 41° to the horizontal. The path of the child through the air is shown in Fig. 3.2.

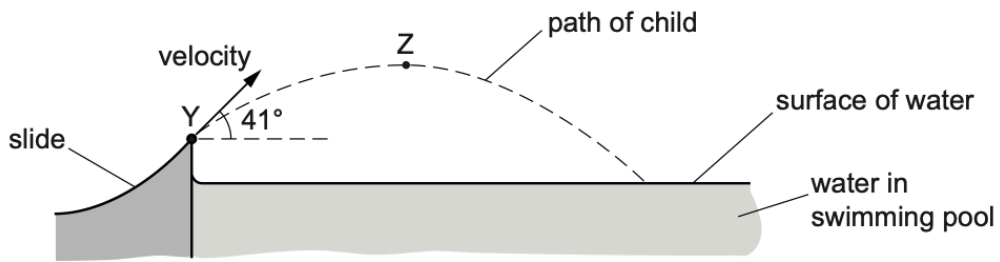

Fig. 3.2 (not to scale)

Point Z is the highest point on the path of the child through the air. Assume that air resistance is negligible.

Calculate the speed of the child at:

- (i) point Y

speed = ms^{-1} [2]

- (ii) point Z.

speed = ms^{-1} [2]

[Total: 8]

Q10 (a) State what is meant by *work done*.

.....
..... [1]

(b) A beach ball is released from a balcony at the top of a tall building. The ball falls vertically from rest and reaches a constant (terminal) velocity. The gravitational potential energy of the ball decreases by 60 J as it falls from the balcony to the ground. The ball hits the ground with speed 16 m s^{-1} and kinetic energy 23 J.

(i) Show that the mass of the ball is 0.18 kg.

[2]

(ii) Calculate the height of the balcony above the ground.

height = m [2]

(iii) Determine the average resistive force acting on the ball as it falls from the balcony to the ground.

average resistive force = N [2]

- (c) State and explain the variation, if any, in the magnitude of the acceleration of the ball in (b) during the time interval when the ball is moving downwards **before** it reaches constant (terminal) velocity.

.....
.....
.....
.....
.....
..... [3]

[Total: 10]

MJ20/22/Q3

- Q11 (a) Explain what is meant by *work done*.

.....
..... [1]

- (b) A ball of mass 0.42 kg is dropped from the top of a building. The ball falls from rest through a vertical distance of 78 m to the ground. Air resistance is significant so that the ball reaches constant (terminal) velocity before hitting the ground. The ball hits the ground with a speed of 23 m s^{-1} .

- (i) Calculate, for the ball falling from the top of the building to the ground:

1. the decrease in gravitational potential energy

decrease in gravitational potential energy = J [2]

2. the increase in kinetic energy.

increase in kinetic energy = J [2]

(ii) Use your answers in (b)(i) to determine the average resistive force acting on the ball as it falls from the top of the building to the ground.

average resistive force = N [2]

(c) The ball in (b) is dropped at time $t = 0$ and hits the ground at time $t = T$. The acceleration of free fall is g .

On Fig. 3.1, sketch a line to show the variation of the acceleration a of the ball with time t from time $t = 0$ to $t = T$.

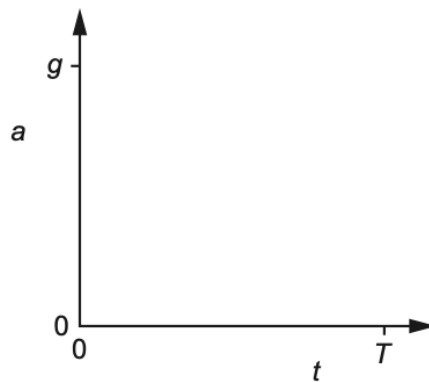

Fig. 3.1

[2]

[Total: 9]

Q12 Define:

(i) *displacement*

.....
.....[1]

(ii) *acceleration.*

.....
.....[1]

(b) A man wearing a wingsuit glides through the air with a constant velocity of 47 m s^{-1} at an angle of 24° to the horizontal. The path of the man is shown in Fig. 2.1.

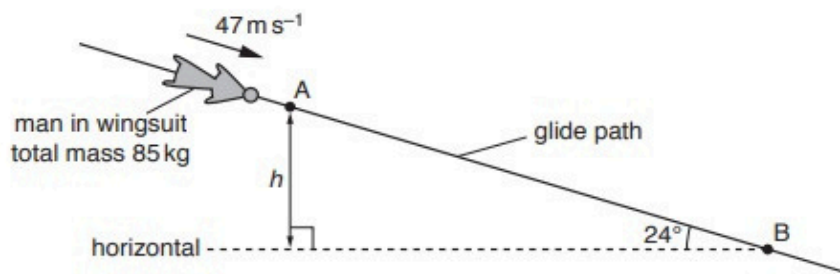

Fig. 2.1 (not to scale)

The total mass of the man and the wingsuit is 85 kg . The man takes a time of 2.8 minutes to glide from point A to point B.

(i) With reference to the motion of the man, state and explain whether he is in equilibrium.

.....
.....
.....
.....[2]

(ii) Show that the difference in height h between points A and B is 3200 m .

[1]

(iii) For the movement of the man from A to B, determine:

1. the decrease in gravitational potential energy

decrease in gravitational potential energy = J [2]

2. the magnitude of the force on the man due to air resistance.

force = N [2]

(iv) The pressure of the still air at A is 63kPa and at B is 92kPa. Assume the density of the air is constant between A and B.

Determine the density of the air between A and B.

density = kg m^{-3} [2]

[Total: 11]

Q13 (a) (i) Define *power*.

.....
..... [1]

(ii) State what is meant by *gravitational potential energy*.

.....
..... [1]

(b) An aircraft of mass 1200 kg climbs upwards with a constant velocity of 45 m s^{-1} , as shown in Fig. 3.1.

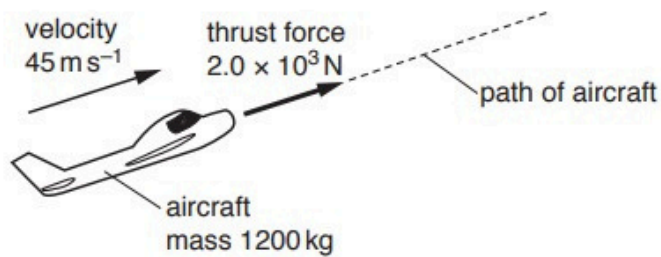

Fig. 3.1 (not to scale)

The aircraft's engine produces a thrust force of $2.0 \times 10^3 \text{ N}$ to move the aircraft through the air. The rate of increase in height of the aircraft is 3.3 m s^{-1} .

(i) Calculate the power produced by the thrust force.

power = W [2]

(ii) Determine, for a time interval of 3.0 minutes,

1. the work done by the thrust force to move the aircraft,

work done = J [2]

2. the increase in gravitational potential energy of the aircraft,

increase in gravitational potential energy = J [2]

3. the work done against air resistance.

work done = J [1]

(iii) Use your answer in (b)(ii) part 3 to calculate the force due to air resistance acting on the aircraft.

force = N [1]

(iv) With reference to the motion of the aircraft, state and explain whether the aircraft is in equilibrium.

.....
.....
..... [2]

[Total: 12]

Q14 (a) State what is meant by *kinetic energy*.

.....
.....[1]

(b) A cannon fires a shell vertically upwards. The shell leaves the cannon with a speed of 80 m s^{-1} and a kinetic energy of 480 J . The shell then rises to a maximum height of 210 m . The effect of air resistance is significant.

(i) Show that the mass of the shell is 0.15 kg .

[2]

(ii) For the movement of the shell from the cannon to its maximum height, calculate

1. the gain in gravitational potential energy,

gain in gravitational potential energy = J [2]

2. the work done against air resistance.

work done = J [1]

(iii) Determine the average force due to the air resistance acting on the shell as it moves from the cannon to its maximum height.

force = N [2]

- (iv) The shell leaves the cannon at time $t = 0$ and reaches maximum height at time $t = T$.

On Fig. 2.1, sketch the variation with time t of the velocity v of the shell from time $t = 0$ to time $t = T$. Numerical values of v and t are not required.

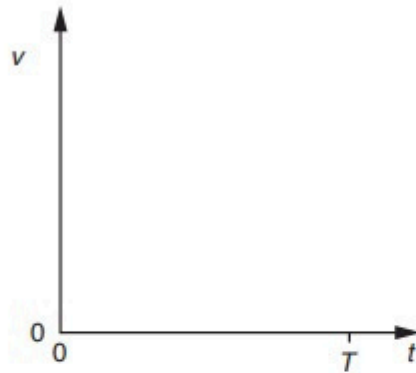

Fig. 2.1

[2]

- (v) The force due to the air resistance is a vector quantity.

Compare the force due to the air resistance acting on the shell as it rises with the force due to the air resistance as it falls.

.....

.....

.....

.....

.....

..... [2]

[Total: 12]

Q15 A ball is thrown vertically upwards towards a ceiling and then rebounds, as illustrated in Fig. 3.1.

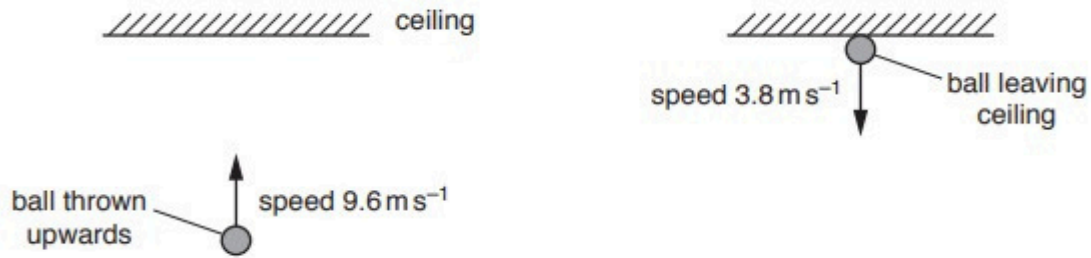

Fig. 3.1

The ball is thrown with speed 9.6 m s^{-1} and takes a time of 0.37 s to reach the ceiling. The ball is then in contact with the ceiling for a further time of 0.085 s until leaving it with a speed of 3.8 m s^{-1} . The mass of the ball is 0.056 kg . Assume that air resistance is negligible.

(a) Show that the ball reaches the ceiling with a speed of 6.0 m s^{-1} .

[1]

(b) Calculate the height of the ceiling above the point from which the ball was thrown.

height = m [2]

(c) Calculate

(i) the increase in gravitational potential energy of the ball for its movement from its initial position to the ceiling,

increase in gravitational potential energy = J [2]

(ii) the decrease in kinetic energy of the ball while it is in contact with the ceiling.

decrease in kinetic energy = J [2]

(d) State how Newton's third law applies to the collision between the ball and the ceiling.

.....
.....
.....
..... [2]

(e) Calculate the change in momentum of the ball during the collision.

change in momentum = N s [2]

(f) Determine the magnitude of the average force exerted by the ceiling on the ball during the collision.

average force = N [2]

[Total: 13]

Q16

(a) Explain what is meant by

(i) *work done*,

.....
.....[1]

(ii) *kinetic energy*.

.....
.....[1]

(b) A leisure-park ride consists of a carriage that moves along a railed track. Part of the track lies in a vertical plane and follows an arc XY of a circle of radius 13 m, as shown in Fig. 2.1.

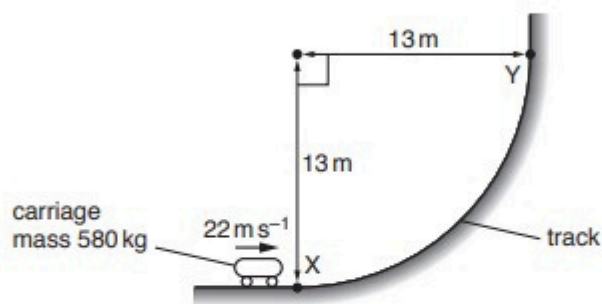

Fig. 2.1

The mass of the carriage is 580 kg. At point X, the carriage has velocity 22 m s^{-1} in a horizontal direction. The velocity of the carriage then decreases to 12 m s^{-1} in a vertical direction at point Y.

(i) For the carriage moving from X to Y

1. show that the decrease in kinetic energy is $9.9 \times 10^4 \text{ J}$,

[2]

2. calculate the gain in gravitational potential energy.

gain in gravitational potential energy = J [2]

(ii) Show that the length of the track from X to Y is 20 m.

[1]

(iii) Use your answers in (b)(i) and (b)(ii) to calculate the average resistive force acting on the carriage as it moves from X to Y.

resistive force = N [2]

(iv) Describe the change in the direction of the linear momentum of the carriage as it moves from X to Y.

.....
..... [1]

(v) Determine the magnitude of the change in linear momentum when the carriage moves from X to Y.

change in momentum = N s [3]

[Total: 13]

Q17

(a) State what is meant by *work done*.

.....
..... [1]

(b) A beach ball is released from a balcony at the top of a tall building. The ball falls vertically from rest and reaches a constant (terminal) velocity. The gravitational potential energy of the ball decreases by 60 J as it falls from the balcony to the ground. The ball hits the ground with speed 16 m s^{-1} and kinetic energy 23 J.

(i) Show that the mass of the ball is 0.18 kg.

[2]

(ii) Calculate the height of the balcony above the ground.

height = m [2]

(iii) Determine the average resistive force acting on the ball as it falls from the balcony to the ground.

average resistive force = N [2]

(c) State and explain the variation, if any, in the magnitude of the acceleration of the ball in (b) during the time interval when the ball is moving downwards **before** it reaches constant (terminal) velocity.

.....

.....

.....

.....

.....

..... [3]

[Total: 10]



Q18

(a) Define *velocity*.

.....
..... [1]

(b) A remote-controlled toy aircraft is flying horizontally in a wind. Fig. 3.1 shows the velocity vectors, to scale, of the wind and of the aircraft in still air.

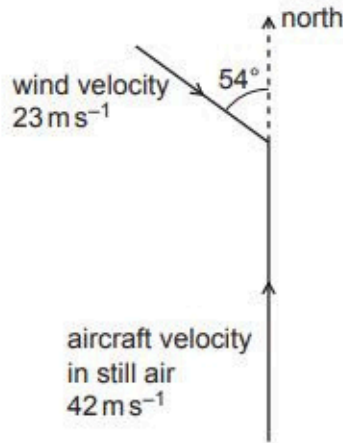

Fig. 3.1

The velocity of the aircraft in still air is 42 m s^{-1} to the north. The velocity of the wind is 23 m s^{-1} in a direction of 54° east of south.

Determine the magnitude of the resultant velocity of the aircraft.

magnitude of velocity = m s^{-1} [2]

- (c) The engine of the aircraft in (b) stops. The aircraft then glides towards the ground with a constant velocity at an angle θ to the horizontal, as illustrated in Fig. 3.2.

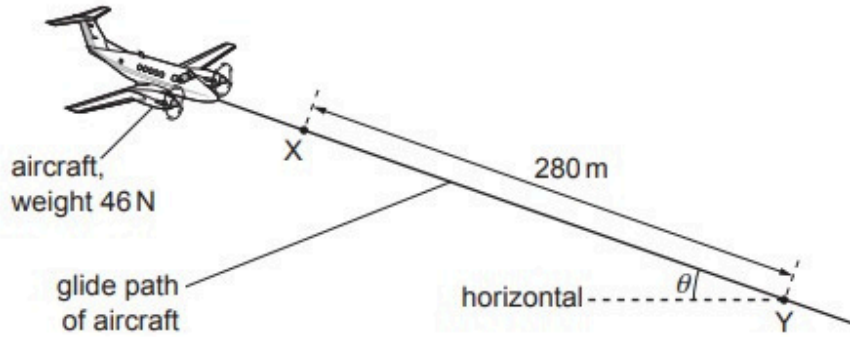

Fig. 3.2 (not to scale)

The aircraft has a weight of 46 N and travels a distance of 280 m from point X to point Y. The change in gravitational potential energy of the aircraft for its movement from X to Y is 6100 J.

Assume that there is now no wind.

- (i) Calculate angle θ .

$\theta = \dots\dots\dots^\circ$ [3]

- (ii) Calculate the magnitude of the force acting on the aircraft due to air resistance.

force = $\dots\dots\dots$ N [2]

- (d) The aircraft in (c) travels from X to Y in a time of 14 s. Fig. 3.3 shows that, as the aircraft travels from X to Y, it moves directly towards an observer who is standing on the ground.

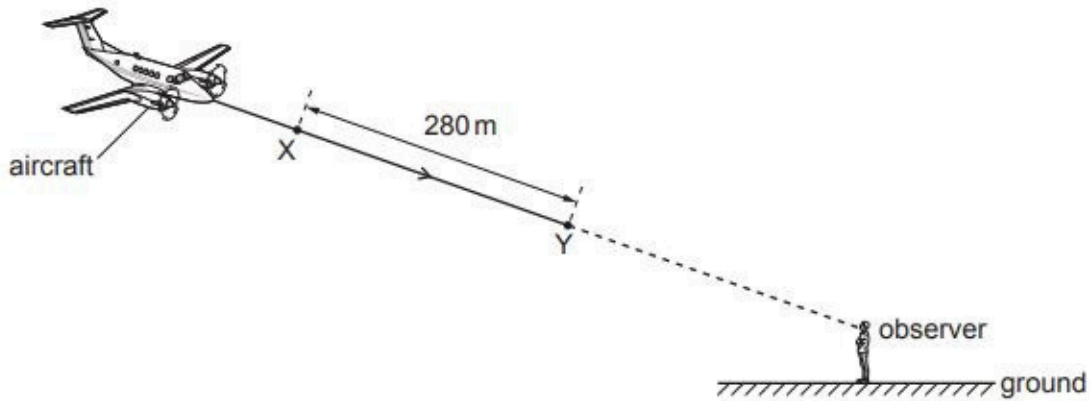

Fig. 3.3 (not to scale)

The aircraft emits sound as it travels from X to Y. The observer hears sound of frequency 450 Hz. The speed of the sound in the air is 340 m s^{-1} .

Calculate the frequency of the sound that is emitted by the aircraft.

frequency = Hz [3]

[Total: 11]

Q19

(a) State **two** conditions for an object to be in equilibrium.

1.
.....
2.
.....
- [2]

(b) A sphere of weight 2.4N is suspended by a wire from a fixed point P. A horizontal string is used to hold the sphere in equilibrium with the wire at an angle of 53° to the horizontal, as shown in Fig. 3.1.

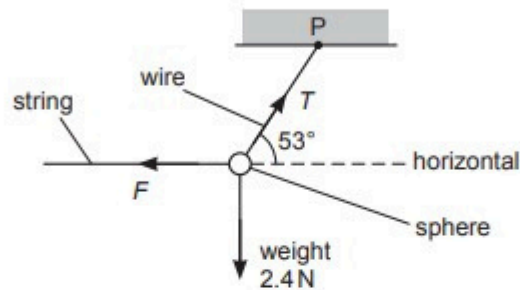

Fig. 3.1 (not to scale)

(i) Calculate:

1. the tension T in the wire

$T = \dots\dots\dots$ N

2. the force F exerted by the string on the sphere.

$F = \dots\dots\dots$ N
[2]

(ii) The wire has a circular cross-section of diameter 0.50 mm. Determine the stress σ in the wire.

$\sigma = \dots\dots\dots$ Pa [3]

- (c) The string is disconnected from the sphere in (b). The sphere then swings from its initial rest position A, as illustrated in Fig. 3.2.

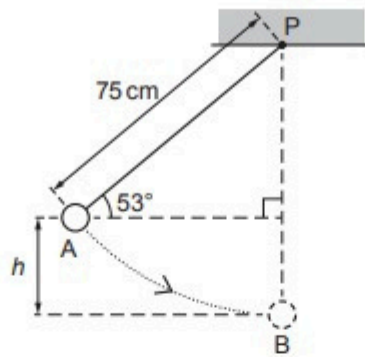

Fig. 3.2 (not to scale)

The sphere reaches maximum speed when it is at the bottom of the swing at position B. The distance between P and the centre of the sphere is 75 cm. Air resistance is negligible and energy losses at P are negligible.

- (i) Show that the vertical distance h between A and B is 15 cm.

[1]

- (ii) Calculate the change in gravitational potential energy of the sphere as it moves from A to B.

change in gravitational potential energy = J [2]

- (iii) Use your answer in (c)(ii) to determine the speed of the sphere at B. Show your working.

speed = ms^{-1} [3]

[Total: 13]

Q20

(a) Explain what is meant by *work done*.

.....
..... [1]

(b) A ball of mass 0.42 kg is dropped from the top of a building. The ball falls from rest through a vertical distance of 78 m to the ground. Air resistance is significant so that the ball reaches constant (terminal) velocity before hitting the ground. The ball hits the ground with a speed of 23 m s^{-1} .

(i) Calculate, for the ball falling from the top of the building to the ground:

1. the decrease in gravitational potential energy

decrease in gravitational potential energy = J [2]

2. the increase in kinetic energy.

increase in kinetic energy = J [2]

(ii) Use your answers in (b)(i) to determine the average resistive force acting on the ball as it falls from the top of the building to the ground.

average resistive force = N [2]

Cyrus Ishaq



ISL, BLL, BCCG, LGS, Roots IVY P5
+923008471504

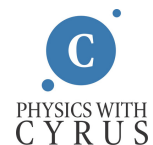

- (c) The ball in (b) is dropped at time $t = 0$ and hits the ground at time $t = T$. The acceleration of free fall is g .

On Fig. 3.1, sketch a line to show the variation of the acceleration a of the ball with time t from time $t = 0$ to $t = T$.

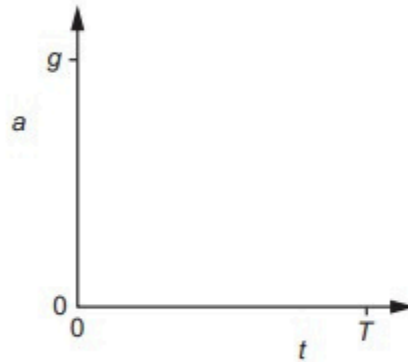

Fig. 3.1

[2]

[Total: 9]

Q21

(a) A resultant force F moves an object of mass m through distance s in a straight line. The force gives the object an acceleration a so that its speed changes from initial speed u to final speed v .

(i) State an expression for:

1. the work W done by the force, in terms of a , m and s

$$W = \dots\dots\dots [1]$$

2. the distance s , in terms of a , u and v .

$$s = \dots\dots\dots [1]$$

(ii) Use your answers in (i) to show that the kinetic energy of the object is given by

$$\text{kinetic energy} = \frac{1}{2} \times \text{mass} \times (\text{speed})^2.$$

Explain your working.

[2]

(b) A ball of mass 0.040 kg is projected into the air from horizontal ground, as illustrated in Fig. 2.1.

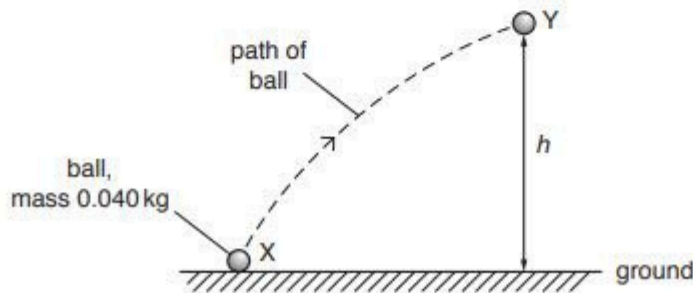

Fig. 2.1

The ball is launched from a point X with a kinetic energy of 4.5 J . At point Y, the ball has a speed of 9.5 m s^{-1} . Air resistance is negligible.

(i) For the movement of the ball from X to Y, draw a solid line on Fig. 2.1 to show:

1. the distance moved (label this line D)
2. the displacement (label this line S).

[2]

(ii) By consideration of energy transfer, determine the height h of point Y above the ground.

$h = \dots\dots\dots$ m [3]

(iii) On Fig. 2.2, sketch the variation of the kinetic energy of the ball with its vertical height above the ground for the movement of the ball from X to Y. Numerical values are not required.

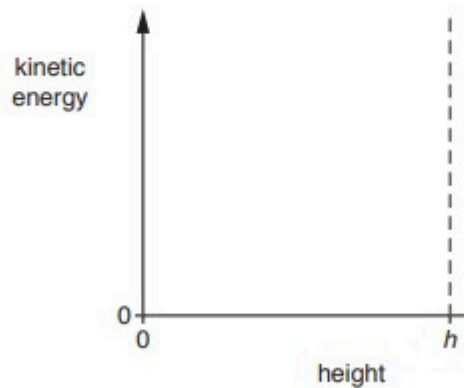

Fig. 2.2

[2]

[Total: 11]

Q1 (a)	the point where (all) the weight (of the object) is taken to act	B1
2(b)(i)	(54×0.45) or (2.4×0.95) or $(T \sin 30^\circ \times 1.3)$	C1
	$(54 \times 0.45) = (2.4 \times 0.95) + (T \sin 30^\circ \times 1.3)$	C1
	$T = 34 \text{ N}$	A1
2(b)(ii)	resultant moment = $(54 \times 0.45) - (2.4 \times 0.95)$ or $(34 \sin 30^\circ \times 1.3)$ = 22 N m	A1
2(c)(i)	$(\Delta)E = mg(\Delta)h$ or $W(\Delta)h$	C1
	= 2.4×1.8	A1
	= 4.3 J	
2(c)(ii)	$E = \frac{1}{2}mv^2$	C1
	= $\frac{1}{2} \times (2.4/9.81) \times 3.4^2$	C1
	= 1.4 J (at X)	
	kinetic energy at Y = $4.3 + 1.4$ = 5.7 J	A1
	or	
	$\frac{1}{2}mv^2 = \frac{1}{2}mu^2 + mg(\Delta)h$	(C1)
	$v^2 = 3.4^2 + 2 \times 9.81 \times 1.8$ $v^2 = 46.9$ so $v = 6.85 \text{ (ms}^{-1}\text{)}$ $KE = \frac{1}{2} \times (2.4/9.81) \times 6.85^2$	(C1)
	= 5.7 J	(A1)
2(c)(iii)	no variation or acceleration is (always) vertically downwards	B1
2(c)(iv)	horizontal straight line at a non-zero value of velocity	B1
Q2 (i)	(component =) $4.8 \sin 30^\circ = 2.4 \text{ (N)}$	A1
2(a)(ii)	(8.2×0.50) or $(W \times 0.60)$ or (0.30×0.80) or (2.4×1.2)	C1
	$(8.2 \times 0.50) = (W \times 0.60) + (0.30 \times 0.80) + (2.4 \times 1.2)$	C1
	$W = 1.6 \text{ N}$	A1
2(a)(iii)	force = $4.8 \cos 30^\circ$ = 4.2 N	A1

2(c)(i)	$((\Delta)E) = mg(\Delta)h$ or $W(\Delta)h$	C1
	$= 0.30 \times 0.090$	A1
	$= 0.027 \text{ J}$	
2(c)(ii)	$E = \frac{1}{2}mv^2$	C1
	$E = 0.044 - 0.027 (= 0.017)$	C1
	$v^2 = (2 \times 0.017) / (0.30 / 9.81)$ (where v = speed at A)	A1
	$v = 1.1 \text{ m s}^{-1}$	
	or	
	$E = \frac{1}{2}mv^2$	(C1)
	$0.044 = \frac{1}{2} \times (0.30 / 9.81) \times v^2$ (where v = speed at B)	(C1)
$(v^2 = 2.88)$		
	$v^2 = u^2 + 2as$ (where u = speed at A)	
	$2.88 = u^2 + 2 \times 9.81 \times 0.090$	
	$u = 1.1 \text{ m s}^{-1}$	(A1)
2(c)(iii)	(gravitational / resultant) force / weight is vertical	B1
2(c)(iv)	straight line with positive gradient starting from non-zero value of v_y at time t_A to a time t_B	B1

Q3 a)(i)	work done per unit time	B1
3(a)(ii)	$W = Fs$	B1
	$P = Fs / t$ <u>and</u> (so) $P = Fv$	B1
3(b)	$(F =) 130 \times 10^3 / 25 = 5200 \text{ (N)}$	A1
3(c)(i)	(component of weight =) $mg \sin \theta$	A1
3(c)(ii)	F (along slope due to weight) = $36\,000 \times 9.81 \times \sin 1.4^\circ$ (= 8600 N)	C1
	(total) $F = 5200 + 36\,000 \times 9.81 \times \sin 1.4^\circ$ (= 13 800 N)	C1
	$P = 13\,800 \times 25$ = $350 \times 10^3 \text{ (W)}$ = 350 kW	A1

Q4 (i)	work (done) / time (taken)	B1
3(a)(ii)	$W = Fx$ or $E = Fx$	B1
	$(P =) Fx / t = Fv$ or $P = Fvt / t = Fv$	B1
3(b)(i)	$T = 430 \sin 11^\circ$ or $430 \cos 79^\circ$	C1
	$= 82 \text{ N}$	A1
3(b)(ii)	speed = $56 / 82$ $= 0.68 \text{ m s}^{-1}$	A1
3(b)(iii)	no change in kinetic energy (of block)	B1
3(b)(iv)	(input power) = $56 / 0.80$ $(= 70 \text{ W})$	C1
	time taken = $1.2 \times 10^3 / 70$ $= 17 \text{ s}$	A1
	or	
	(useful energy) = $1200 \times 80 / 100$ $(= 960 \text{ J})$	(C1)
	time taken = $960 / 56$ $= 17 \text{ s}$	(A1)

Q5 (a)	work (done) = force \times displacement	M1
	(force = mg and distance = Δh)	A1
	(so) work (done) = $mg\Delta h$ and work = $\Delta E_{(P)}$ (so $\Delta E_{(P)} = mg\Delta h$)	
4(b)	gravitational potential (energy) to heat/thermal (energy)	B1
4(c)(i)	$P = mg(\Delta)h / (\Delta)t$ or Fv	C1
	$P = (0.60 \times 9.81 \times 1.4) / 4.0$ or $0.60 \times 9.81 \times (1.4 / 4.0)$ $= 2.1 \text{ W}$	A1
4(c)(ii)	$P = I^2R$ or IV or V^2 / R	C1
	$= 0.09^2 \times 47$ or 0.09×4.23 or $4.23^2 / 47$	A1
	$= 0.38 \text{ W}$	
4(c)(iii)	efficiency = $P_{\text{out}} / P_{\text{in}} (\times 100)$ or $E_{\text{out}} / E_{\text{in}} (\times 100)$	C1
	$= 0.38 / 2.1 (\times 100)$ or $0.38 \times 4.0 / 2.1 \times 4.0 (\times 100)$	A1
	$= 0.18$ or 18%	

Q6	(a)	ratio = $300 / 3200$ = 0.094	A1
	4(b)	$E = \frac{1}{2}mv^2$ or $E \propto v^2$ ratio = $(0.094)^{0.5}$ = 0.31	C1 A1
4(c)		work (done against frictional force) = $3200 - 300$ (=2900)	C1
		length = $2900 / 76$ = 38 m	A1

Q7	(a)	work (done) / time (taken)	B1
	3(b)(i)	zero / 0 J	A1
3(b)(ii)		work done = 440×25 = 1.1×10^4 J	A1
3(c)(i)		$(\Delta)E_{(P)} = mg(\Delta)h$ $h = 4.8 \times 10^4 / (1700 \times 9.81)$ = 2.9 m	C1 A1
	3(c)(ii)	$\theta = \sin^{-1}(2.9 / 25)$ = 6.7°	A1
3(d)		work done = $4.8 \times 10^4 + 1.1 \times 10^4$ (= 5.9×10^4 J)	C1
		time = $5.9 \times 10^4 / 1.7 \times 10^4$ = 3.5 s	A1

Q8	a)(i)	$P = Fv$ = 18×1.4 = 25 W	C1 A1	
		2(a)(ii)	$a = F / m$ $a = 18 / 72 = 0.25$ (ms^{-2}) $t = 1.4 / 0.25$ = 5.6 s	C1 C1 A1
		2(b)(i)	$a = (54 - 18) / 72$ or $36 / 72$ (= 0.50 ms^{-2}) $v^2 = 2 \times 0.50 \times 9.5$ $v = 3.1 \text{ ms}^{-1}$	C1 C1 A1
2(b)(ii)		$W = 54 \times 9.5$ = 510 J	A1	
2(b)(iii)		curved line from the origin	M1	
		gradient of line increases	A1	
2(c)		(force due to) air resistance increases/changes/not constant or air resistance increases with speed	B1	

Q9 3(a)	$(\Delta)E = mg(\Delta)h$ or $W(\Delta)h$	C1
	$= 330 \times (4.0 - 1.1)$	A1
	$= 960 \text{ J}$	
3(b)	(work =) $960 - 540$	C1
	(= 420 J)	
	distance moved = $(960 - 540) / 52$	A1
	$= 8.1 \text{ m}$	
3(c)(i)	$E = \frac{1}{2}mv^2$	C1
	$540 = \frac{1}{2} \times (330 / 9.81) \times v^2$	A1
	$v = 5.7 \text{ m s}^{-1}$	
3(c)(ii)	speed = horizontal component of velocity	C1
	$= 5.7 \times \cos 41^\circ$	
	$= 4.3 \text{ m s}^{-1}$	A1

Q10 (a)	force \times displacement in the direction of the force	B1
2(b)(i)	$E = \frac{1}{2}mv^2$	C1
	(m =) $23 \times 2 / 16^2 = 0.18 \text{ (kg)}$	A1
2(b)(ii)	$(\Delta)E = mg(\Delta)h$	C1
	$60 = 0.18 \times 9.81 \times h$	
	$h = 34 \text{ m}$	A1
2(b)(iii)	(work done =) $60 - 23$	C1
	$= 37 \text{ (J)}$	
	average resistive force = $37 / 34$	A1
	$= 1.1 \text{ N}$	
2(c)	air resistance (acting on ball) increases	B1
	resultant force (on ball) decreases or weight constant and air resistance increases	B1
	acceleration decreases	B1

Q11 (a)	(work done =) force \times displacement in direction of the force	B1
3(b)(i)	1. $(\Delta)E = mg(\Delta)h$	C1
	$= 0.42 \times 9.81 \times 78$	A1
	$= 320 \text{ J}$	
	2. $E = \frac{1}{2}mv^2$	C1
	$(\Delta)E = \frac{1}{2} \times 0.42 \times 23^2$	A1
	$= 110 \text{ J}$	
3(b)(ii)	work done = $320 - 110$ (= 210 N)	C1
	average resistive force = $210 / 78$	A1
	$= 2.7 \text{ N}$	
3(c)	downward sloping line from (0, g) to a non-zero value on the time axis	M1
	line is curved with a gradient that becomes less negative and the line meets t-axis at time $t < T$	A1

Question	Answer	Marks
Q12 2(a)(i)	distance in a specified direction (from a point)	B1
2(a)(ii)	change in velocity / time (taken)	B1
2(b)(i)	constant velocity so no resultant force	B1
	no resultant force so in equilibrium	B1
2(b)(ii)	(difference in height =) $47 \times 2.8 \times 60 \times \sin 24^\circ = 3200 \text{ m}$	A1

Question	Answer	Marks
2(b)(iii)	1 $(\Delta)E = mg(\Delta)h$ $= 85 \times 9.81 \times 3200$	C1
	$= 2.7 \times 10^6 \text{ J}$	A1
	2 <u>In terms of energy:</u> work done = $2.7 \times 10^6 \text{ J}$ force = $2.7 \times 10^6 / (47 \times 2.8 \times 60)$	C1
	$= 340 \text{ N}$	A1
	<u>In terms of forces:</u> component of weight along path = force due to air resistance force = $85 \times 9.81 \times \sin 24^\circ$	(C1)
	$= 340 \text{ N}$	(A1)
2(b)(iv)	$(\Delta)\rho = \rho g(\Delta)h$ $(92 - 63) \times 10^3 = \rho \times 9.81 \times 3200$	C1
	$\rho = 0.92 \text{ kg m}^{-3}$	A1

Question	Answer	Marks
Q13 a(i)	work (done)/time (taken)	B1
3(a)(ii)	energy of a mass due to its position in a gravitational field	B1
3(b)(i)	$P = Fv$	C1
	$= 2.0 \times 10^3 \times 45$	A1
	$= 9.0 \times 10^4 \text{ W}$	
3(b)(ii)	1. $W = (2.0 \times 10^3) \times (45 \times 3.0 \times 60)$ or $W = 9.0 \times 10^4 \times 3.0 \times 60$	C1
	$W = 1.6 \times 10^7 \text{ J}$	A1
	2. $(\Delta)E_P = mg(\Delta)h$	C1
	$= 1200 \times 9.81 \times 3.3 \times 3.0 \times 60$	A1
	$= 7.0 \times 10^6 \text{ J}$	
	3. $W = 1.6 \times 10^7 - 7.0 \times 10^6$	A1
	$= 9.0 \times 10^6 \text{ J}$	
3(b)(iii)	force = $(9.0 \times 10^6) / (45 \times 3.0 \times 60)$	A1
	$= 1.1 \times 10^3 \text{ N}$	
3(b)(iv)	constant velocity so no resultant force	B1
	no resultant force so in equilibrium	B1

Question	Answer	Marks
Q14 (a)	energy (of a mass/body/object) due to motion/speed/velocity	B1
2(b)(i)	$E = \frac{1}{2}mv^2$	C1
	$480 = \frac{1}{2} \times m \times 80^2$ so $m = 0.15 \text{ kg}$	A1
2(b)(ii)	1. $E = mgh$ or $\Delta E = mg\Delta h$	C1
	$= 0.15 \times 9.81 \times 210$	A1
	$= 310 \text{ J}$	
2(b)(iii)	2. work done = $480 - 310$	A1
	$= 170 \text{ J}$	
2(b)(iv)	work done = Fs	C1
	force = $170/210$	A1
	$= 0.81 \text{ N}$	
2(b)(v)	curved line from positive value on v -axis to $(T, 0)$	M1
	magnitude of gradient decreases	A1
2(b)(v)	as shell rises force decreases and as shell falls force increases	B1
	as shell rises force is downward and as shell falls force is upward	B1
	or	
	as shell rises the force decreases and is downward	(B1)
	as shell falls the force increases and is upward	(B1)

Question	Answer	Mark
Q15 (a)	$v = u + at$ $v = 9.6 - (9.81 \times 0.37) = 6.0 \text{ ms}^{-1}$	A1
3(b)	$s = \frac{1}{2} \times (9.6 + 6.0) \times 0.37$	C1
	or $6.0^2 = 9.6^2 - (2 \times 9.81 \times s)$	
	or $s = (9.6 \times 0.37) - (\frac{1}{2} \times 9.81 \times 0.37^2)$	
3(b)	or $s = (6.0 \times 0.37) + (\frac{1}{2} \times 9.81 \times 0.37^2)$	
	$s = 2.9 \text{ m}$	A1
3(c)(i)	$(\Delta)E = mg(\Delta)h$	C1
	$\Delta E = 0.056 \times 9.81 \times 2.9$ $= 1.6 \text{ J}$	A1
3(c)(ii)	$E = \frac{1}{2}mv^2$	C1
	$\Delta E = \frac{1}{2} \times 0.056 \times (6.0^2 - 3.8^2)$ $= 0.60 \text{ J}$	A1
3(d)	force on ball (by ceiling) <u>equal</u> to force on ceiling (by ball)	M1
	and opposite (in direction)	A1
3(e)	$(p =) mv$ or 0.056×6.0 or 0.056×3.8	C1
	change in momentum = $0.056 \times (6.0 + 3.8)$ $= 0.55 \text{ N s}$	A1

Question	Answer	Mark
3(f)	resultant force = $0.55/0.085$ (= 6.47N)	C1
	force by ceiling = $6.47 - (0.056 \times 9.81)$ = 5.9N	A1

Question	Answer	Mark
Q16 a)(i)	force \times distance <u>moved</u> in the direction of the force	B1
2(a)(ii)	energy (of a mass/body) due to motion / speed / velocity	B1
2(b)(i)	1 $E = \frac{1}{2}mv^2$ $(\Delta)E = \frac{1}{2} \times 580 \times (22^2 - 12^2) = 9.9 \times 10^4 \text{ J}$	C1 A1
	2 $(\Delta)E = mg(\Delta)h$ $\Delta E = 580 \times 9.81 \times 13$ = $7.4 \times 10^4 \text{ J}$	C1 A1

Question	Answer	Marks
2(b)(ii)	length = $(2\pi \times 13) / 4$ or $(\pi \times 26) / 4$ or $(\pi \times 13) / 2 = 20 \text{ m}$	A1
2(b)(iii)	work done against resistive force = $9.9 \times 10^4 - 7.4 \times 10^4$ average resistive force = $(9.9 \times 10^4 - 7.4 \times 10^4) / 20$ = 1300 N	C1 A1
	2(b)(iv)	from horizontal/right to vertical / up or 90°
2(b)(v)	$p = mv$ or (580×22) or (580×12)	C1
	$\Delta p = [(580 \times 12)^2 + (580 \times 22)^2]^{0.5}$	C1
	= $1.5 \times 10^4 \text{ N s}$	A1

Question	Answer	Mark	
Q17 (a)	force \times displacement in the direction of the force	B1	
2(b)(i)	$E = \frac{1}{2}mv^2$	C1	
	$(m =) 23 \times 2 / 16^2 = 0.18 \text{ (kg)}$	A1	
2(b)(ii)	$(\Delta)E = mg(\Delta)h$ $60 = 0.18 \times 9.81 \times h$ $h = 34 \text{ m}$	C1 A1	
	2(b)(iii)	(work done =) $60 - 23$ = 37 (J)	C1
	average resistive force = $37 / 34$ = 1.1 N	A1	
2(c)	air resistance (acting on ball) increases	B1	
	resultant force (on ball) decreases or weight constant and air resistance increases	B1	
	acceleration decreases	B1	

Question	Answer	Marks
Q18 (a)	change in displacement / time (taken)	B1
3(b)	by calculation: $v^2 = 42^2 + 23^2 - (2 \times 42 \times 23 \times \cos 54^\circ)$ or $v^2 = (42 - 23 \cos 54^\circ)^2 + (23 \sin 54^\circ)^2$ or $v^2 = (42 - 23 \sin 36^\circ)^2 + (23 \cos 36^\circ)^2$	C1
	$v = 34 \text{ m s}^{-1}$	A1
	or	
	by scale diagram: triangle of vector velocities drawn	(C1)
	$v = 34 \text{ m s}^{-1}$ (allow $\pm 1 \text{ m s}^{-1}$ if scale diagram used)	(A1)
3(c)(i)	$(\Delta)E = mg(\Delta)h$ or $(\Delta)E = W(\Delta)h$	C1
	$h = 6100/46$ (= 133 m)	C1
	$\theta = \sin^{-1}(133/280)$ = 28°	A1
3(c)(ii)	force = $6100/280$ or $46 \sin 28^\circ$	C1
	= 22 N	A1
3(d)	$v_{(s)} = 280/14$ (= 20 m s^{-1})	C1
	$f_o = f_s v / (v - v_s)$	C1
	$f_s = 450 \times (340 - 20) / 340$ = 420 Hz	A1

Question	Answer	Marks
Q19 3(a)	resultant force (in any direction) is zero	B1
	resultant torque/moment (about any point) is zero	B1
3(b)(i)	1. $T \sin 53^\circ = 2.4$ $T = 3.0 \text{ N}$	A1
	2. $F = T \cos 53^\circ$ or $F^2 = T^2 - 2.4^2$ $F = 1.8 \text{ N}$	A1
3(b)(ii)	$\sigma = T/A$ or $\sigma = F/A$	C1
	$A = \pi d^2/4$ or $A = \pi r^2$	C1
	$\sigma = 3.0 \times 4 / [\pi \times (0.50 \times 10^{-3})^2]$ = $1.5 \times 10^7 \text{ Pa}$	A1
3(c)(i)	$h = 75 - 75 \sin 53^\circ = 15 \text{ cm}$	A1
3(c)(ii)	$(\Delta)E = mg(\Delta)h$ or $(\Delta)E = W(\Delta)h$	C1
	$(\Delta)E = 2.4 \times 15 \times 10^{-2}$ = 0.36 J	A1
3(c)(iii)	$E = \frac{1}{2}mv^2$	B1
	$0.36 = \frac{1}{2} \times (2.4/9.81) \times v^2$	C1
	$v = 1.7 \text{ m s}^{-1}$	A1

Question	Answer	Marks
Q20 3(a)	(work done =) force \times displacement in direction of the force	B1
3(b)(i)	1. $(\Delta)E = mg(\Delta)h$	C1
	$= 0.42 \times 9.81 \times 78$	A1
	$= 320 \text{ J}$	
	2. $E = \frac{1}{2}mv^2$	C1
	$(\Delta)E = \frac{1}{2} \times 0.42 \times 23^2$	A1
	$= 110 \text{ J}$	
3(b)(ii)	work done = $320 - 110 (= 210 \text{ N})$	C1
	average resistive force = $210 / 78$	A1
	$= 2.7 \text{ N}$	
3(c)	downward sloping line from (0, g) to a non-zero value on the time axis	M1
	line is curved with a gradient that becomes less negative and the line meets t -axis at time $t < T$	A1

Question	Answer	Marks
Q21 1(a)(i)	1. $W = mas$	B1
	2. $s = (v^2 - u^2) / 2a$	B1
2(a)(ii)	W /work equals energy transferred/ <u>gain or change in</u> kinetic energy	B1
	$W (= mas) = ma(v^2 - u^2) / 2a$	B1
	leading to $W = m(v^2 - u^2) / 2$ (so $KE = \frac{1}{2}mv^2$)	
2(b)(i)	1. solid curved line drawn from X to Y along path of ball and labelled D	B1
	2. solid straight line drawn from X to Y and labelled S	B1
2(b)(ii)	$(\Delta)E = mg(\Delta)h$	C1
	$4.5 = (0.040 \times 9.81 \times h) + (\frac{1}{2} \times 0.040 \times 9.5^2)$	C1
	$h = 6.9 \text{ m}$	A1
2(b)(iii)	line with a negative gradient starting from a non-zero value of kinetic energy when the vertical height is zero	M1
	<u>straight</u> line ends at a non-zero value of kinetic energy when the vertical height is h	A1